

WEIGHT = 65 LB  
LENGTH = 42"  
WIDTH = 21"  
HEIGHT = 33"

# HAMMER STRENGTH EQUIPMENT PLGRIP EXPLODED

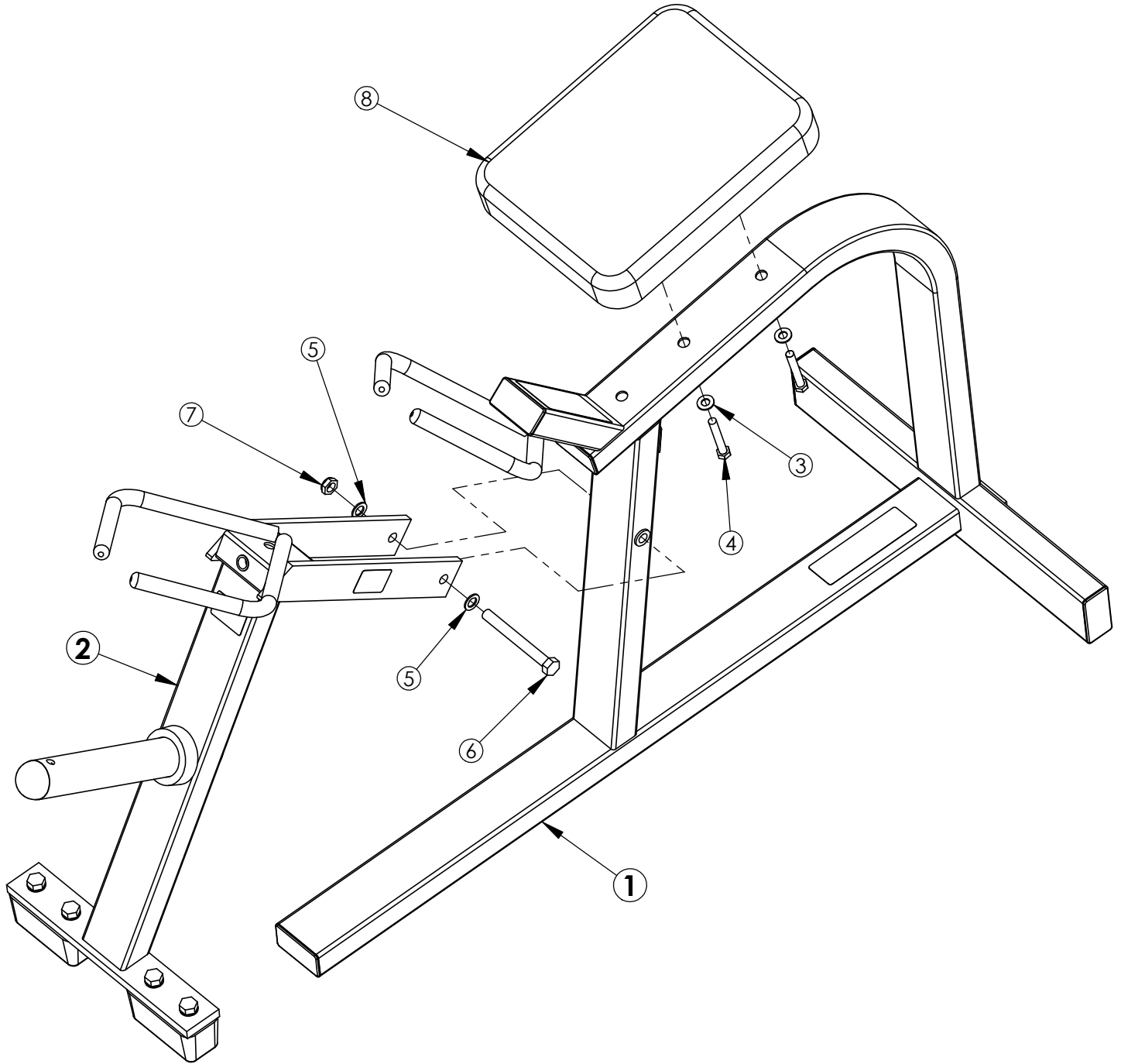

| ITEM NO. | QTY. | PART NO.     | DESCRIPTION                |
|----------|------|--------------|----------------------------|
| 1        | 1    | PLGRIP-CWB-0 | ASSY, PLGRIP, WORKBOX      |
| 2        | 1    | PLGRIP-CMA-2 | ASSY, PLGRIP, MOVEMENT ARM |
| 3        | 2    | WASH.375SAE  | 3/8" SAE FLAT WASHER       |
| 4        | 2    | HHB.375X2.5  | STEEL BOLT 3/8 X 2.5       |
| 5        | 2    | WASH.5STAR   | 1/2" INTERNAL LOCK WASHER  |
| 6        | 1    | HHB.5X4.5Bro | 1/2 X 4 1/2 BOLT BRONZE    |
| 7        | 1    | NUT.5JAMLOCK | 1/2 THIN LOCK NUT          |
| 8        | 1    | U-13-5       | 13X5 PAD                   |

**HAMMER STRENGTH EQUIPMENT  
PLGRIP-CMA-2, ASSY, PLGRIP, MOVEMENT ARM**

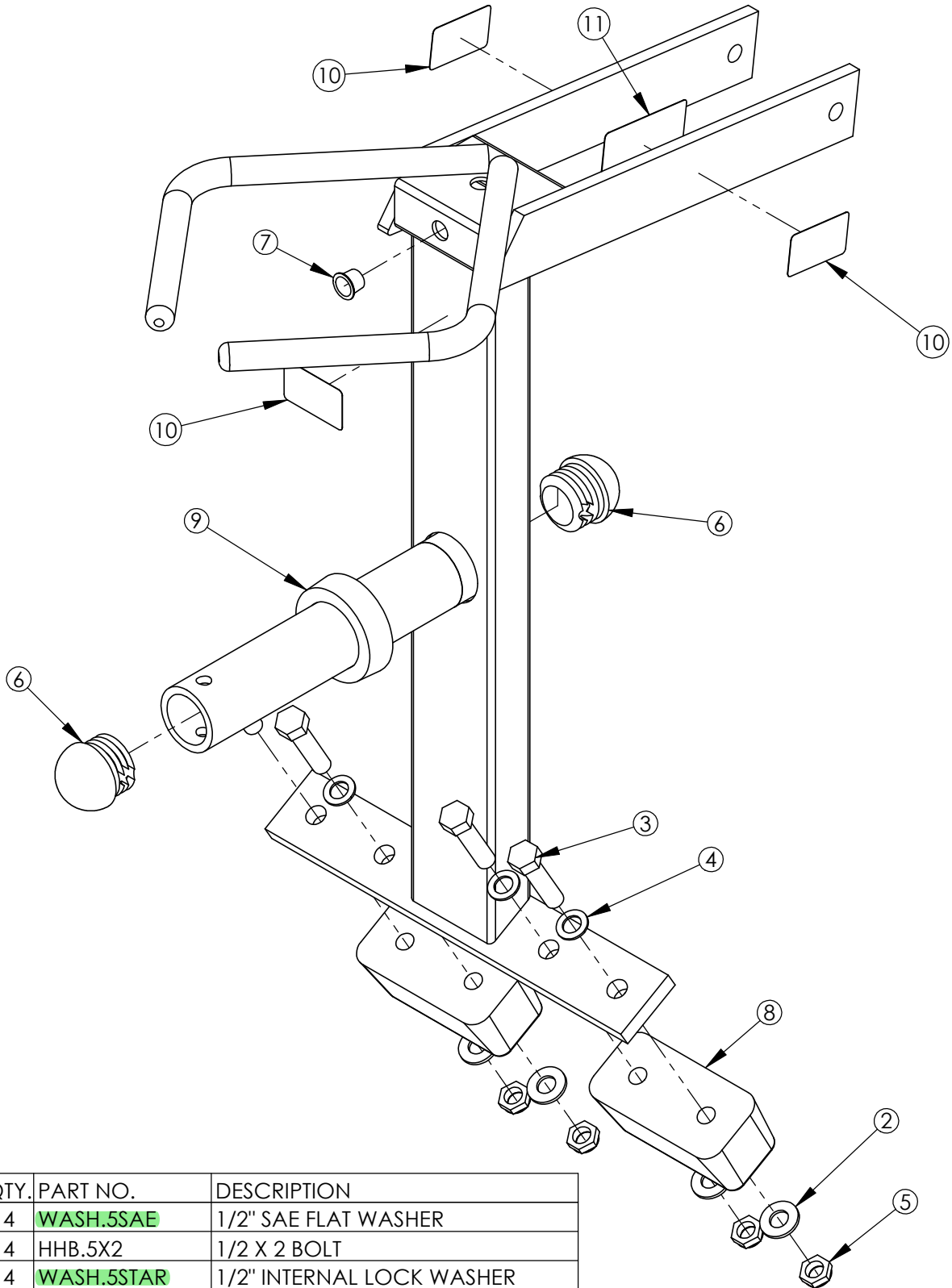

| ITEM NO. | QTY. | PART NO.      | DESCRIPTION               |
|----------|------|---------------|---------------------------|
| 2        | 4    | WASH.5SAE     | 1/2" SAE FLAT WASHER      |
| 3        | 4    | HHB.5X2       | 1/2 X 2 BOLT              |
| 4        | 4    | WASH.5STAR    | 1/2" INTERNAL LOCK WASHER |
| 5        | 4    | NUT.5JAMLOCK  | 1/2 THIN LOCK NUT         |
| 6        | 2    | RUBCAP1-2     | RUBBER CAP #1             |
| 7        | 1    | H-HPLUG (REG) | 9/16IN HOLE PLUG          |
| 8        | 2    | H-BUMP-MED    | MM2 MEDIUM                |
| 9        | 1    | H-RUBRNG      | MM5 RING                  |
| 10       | 3    | STAY CLEAR    | STAY CLEAR DECAL          |
| 11       | 1    | PATENT        | PATENT DECAL              |

WEIGHT = 25 lb  
 LENGTH = 26 1/8"  
 WIDTH = 13 1/4"  
 HEIGHT = 23"

**HAMMER STRENGTH EQUIPMENT  
PLGRIP-CWB-0, ASSY, PLGRIP, WORKBOX**

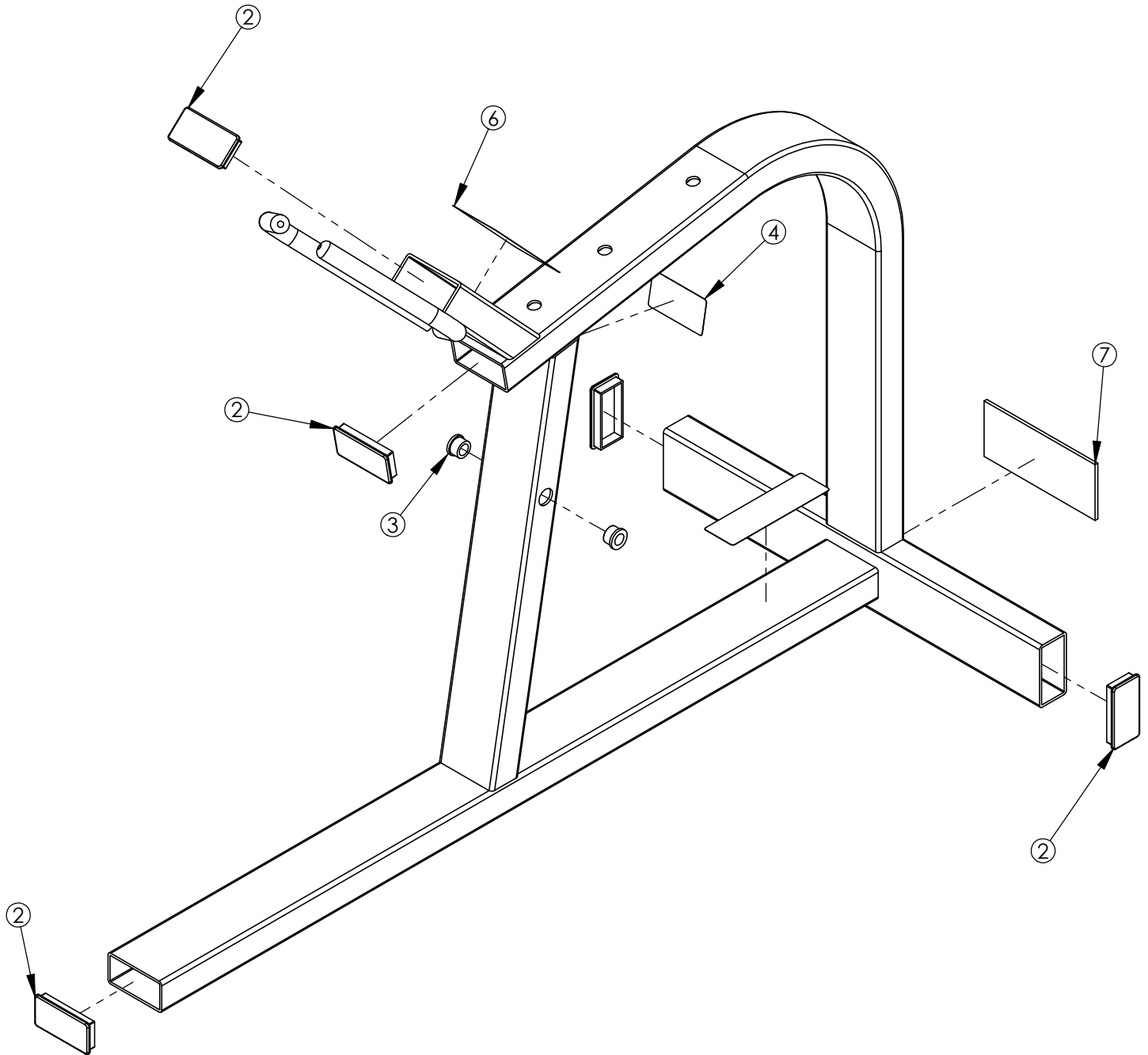

| ITEM NO. | QTY. | PART NO.      | DESCRIPTION                    |
|----------|------|---------------|--------------------------------|
| 2        | 5    | RC1530-1Q1    | CAP:1-1/2 X 3 RECTANGLE PLUG   |
| 3        | 2    | STEELBUSH     | 3/4 I.D. FLANGED DRILL BUSHING |
| 4        | 1    | SERIAL NUMBER | SERIAL NUMBER                  |
| 5        | 1    | GRIPPER       | PRODUCT DECAL                  |
| 6        | 1    | 8773701       | ASTM LABEL                     |
| 7        | 1    | H-NAME PLATE  | NAMEPLATE (45156-P)            |

WEIGHT = 41 lb  
 LENGTH = 41 7/8"  
 WIDTH = 21 3/8"  
 HEIGHT = 33 1/4"